



PLATE MOUNTED AXIAL FLOW FANS

HIB-NP / HIT-NP Series

HIB-NP / HIT-NP

Plate mounted axial flow fans



Outlet louvre shutter side



Inlet guard side

Range of belt driven axial flow fans designed to move large volumes of air. The casings are manufactured from galvanised sheet steel.

Mechanically operated outlet louvre shutter. PVC inlet guard.

All standard models are fitted with an automatic louvre shutter on the outlet side of the fan (Type - NP).

All impellers are manufactured from galvanised sheet steel.

Motors

All motors are IP55 Class F insulation.

Electrical supplies:

Single phase 230V-50Hz.

Three phase 230/400V-50Hz.

On request

The units can be supplied without automatic louvre shutter and replaced with a steel mesh guard on the discharge (Type -N).

The inlet guard can be manufactured from electro welded steel mesh.

A P P L I C A T I O N S



Warehouses



Greenhouses



Agricultural extract or supply applications



Sport centers



Commercial or industrial drying rooms

Compact design



Robust casings manufactured from **galvanised steel sheet**

Automatic louvre shutter on the outlet side (Type- NP)



Multi-bladed shutter automatically **opens and closes** when the fan is switched on and off

Protection guard on the inlet side



Made of PVC

Protected belt-driven assembly



Trapezoidal belt drive protected by a belt guard

■ Technical characteristics

Before making any electrical connection ensure that the voltage and frequency of the mains electrical supply matches that of the fan data plate label.

SINGLE PHASE	Motor Power	Maximum absorbed current	Motor speed	Impeller speed	Maximum air volume	Sound pressure level	Weight
Model	(kW)	(A)	(r.p.m.)	(r.p.m.)	(m ³ /h)	(dB(A))*	(kg)
HIB-800 NP (0,37)	0,37	3	2800	575	13500	71	48
HIB-800 NP (0,55)	0,55	4	2800	650	15700	72	48
HIB-1000 NP (0,37)	0,37	3	1400	420	16900	63	63
HIB-1000 NP (0,55)	0,55	4,4	1400	475	19400	66	64
HIB-1000 NP (0,75)	0,75	5,5	1400	490	21200	67	66
HIB-1250 NP (0,75)	0,75	5,5	1400	430	30500	64	87
HIB-1250 NP (1,1)	1,1	7,6	1400	480	36000	67	90
HIB-1250 NP (1,5)	1,5	10,9	1400	535	40700	69	92

* The sound level corresponds to a pressure value in dB(A) measured in a free field at a distance equivalent to three times the diameter of the blade.

THREE PHASE	Motor Power	Maximum absorbed current	Motor speed	Impeller speed	Maximum air volume	Sound pressure level	Weight
Model	(kW)	(A)	(r.p.m.)	(r.p.m.)	(m ³ /h)	(dB(A))*	(kg)
HIT-800 NP (0,37)	0,37	1,8/1,1	2800	575	13500	71	48
HIT-800NP (0,55)	0,55	2,5/1,4	2800	650	15700	72	48
HIT-1000 NP (0,37)	0,37	2,05/1,2	1400	420	16900	63	63
HIT-1000 NP (0,55)	0,55	2,65/1,53	1400	475	19400	66	64
HIT-1000 NP (0,75)	0,75	3,5/2,0	1400	490	21200	67	66
HIT-1250 NP (0,75)	0,75	3,7/2,1	1400	430	30500	64	87
HIT-1250 NP (1,1)	1,1	4,7/2,72	1400	480	36000	67	90
HIT-1250 NP (1,5)	1,5	6,3/3,66	1400	535	40700	69	92

* The sound level corresponds to a pressure value in dB(A) measured in a free field at a distance equivalent to three times the diameter of the blade.

■ Dimensions (mm)

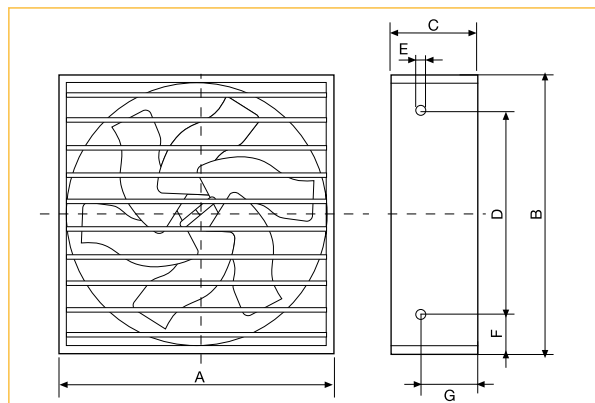

Model	A	B	C	D	Ø E	F	G
HIT or HIB-800	925	925	427	470	10,5	227	165
HIT or HIB-1000	1125	1125	447	685	10,5	345	205
HIT or HIB-1250	1375	1375	480	560	10,5	283	180

■ Mounting accessories

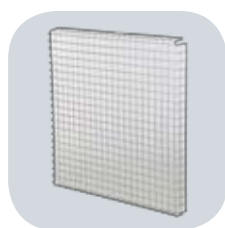

Safety guard kit

Electro-welded steel mesh protection guard with frame to fit at the NP type fan discharge to prevent access to the moving parts. The installations must include this accessory to comply with the European Machinery Directive if the lowest point of the fan is mounted at less than 2,5 m from the floor level.

- Safety guard kit HIT/HIB-800 NP
- Safety guard kit HIT/HIB-1000 NP
- Safety guard kit HIT/HIB-1250 NP

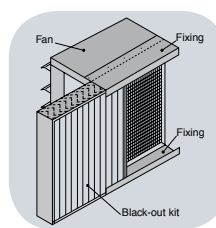

Black-Out Kit

Metallic protection Panel which avoids the entry of natural light. Specially recommended for poultry ventilation applications.

- Black-Out kit HIT/HIB-800 NP
- Black-Out kit HIT/HIB-1000 NP
- Black-Out kit HIT/HIB-1250 NP

■ Performance curves

- Q = Air volume in, m³/hr and m³/s.
- Ps = Static pressure in mmWG and Pa.
- Dry air at 20°C and 760 mmHg.
- Performance data in accordance with ISO 5801 and AMCA 210-99 Standards.

